



PERFORMANCE RANGE

- Flow rate up to **90 l/min** (5.4 m³/h)
- Head up to **100 m**

APPLICATION LIMITS

- Manometric suction lift up to **8 m**
- Liquid temperature between **-10 °C** and **+60 °C**
- Ambient temperature up to **+40 °C**
- Max. working pressure:
 - **6.5 bar** for PK 60-65-70-80
 - **10 bar** for PK 90-100-200-300
- Continuous service **S1**

CONSTRUCTION AND SAFETY STANDARDS

EN 60335-1
IEC 60335-1
CEI 61-150

EN 60034-1
IEC 60034-1
CEI 2-3



CERTIFICATIONS



INSTALLATION AND USE

Suitable for use with clean water that does not contain abrasive particles and liquids that are not chemically aggressive towards the materials from which the pump is made.

Thanks to their reliability, the fact that they are easy to use and are economical, they are ideal for domestic use and in particular for distributing water in combination with small pressure sets and for the irrigation of gardens and allotments.

The pump should be installed in an enclosed environment, or at least sheltered from inclement weather.

PATENTS - TRADE MARKS - MODELS

- Motor bracket: patent n° IT1243605 (reduces the risk of the impeller locking after long periods of inactivity)
- PKm 60° is a registered trade mark
- Registered Italian model n° 72753

OPTIONALS AVAILABLE ON REQUEST

- Special mechanical seal
- Other voltages or 60 Hz frequency
- IP55 class protection

GUARANTEE

2 years subject to terms and conditions

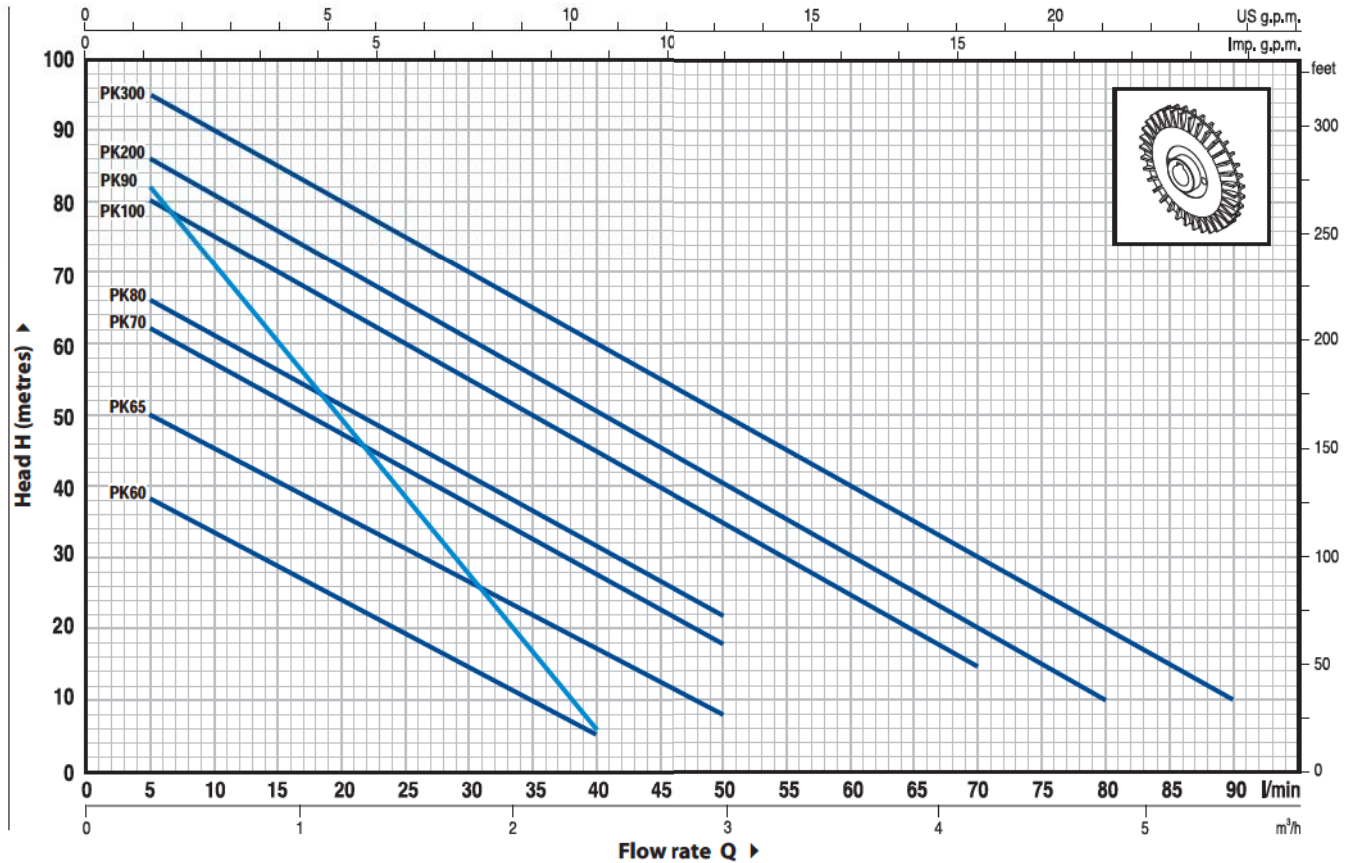
CHARACTERISTIC CURVES AND PERFORMANCE DATA
50 Hz n= 2900 1/min HS= 0 m

MODEL		POWER		Q	H metres																
Single-phase	Three-phase	kW	HP		m³/h	0	0.3	0.6	0.9	1.2	1.5	1.8	2.1	2.4	3.0	3.6	4.2	4.8	5.4		
				l/min	0	5	10	15	20	25	30	35	40	50	60	70	80	90			
PKm 60°	PK 60°	0.37	0.50	H metres	40	38	33.5	29	24	19.5	15	10	5								
PKm 65	PK 65	0.50	0.70		55	50	45.5	40.5	36	31	27	22	17	8							
PKm 70	PK 70	0.60	0.85		65	62	57	52	47	42	37	32	27	18							
PKm 80	PK 80	0.75	1		70	66	61	56	51	46	41	36.5	31	22							
PKm 90	PK 90	0.75	1		90	82	71	60	49	38	27	17	5								
PKm 100	PK 100	1.1	1.5		85	80	75	70	65	60	55	50	45	35	25	15					
PKm 200	PK 200	1.5	2		90	86	81	76	71	65.5	60	55	50	40	30	20	10				
-	PK 300	2.2	3		100	95	90	85	80	75	70	65	60	50	40	30	20	10			

Q = Flow rate H = Total manometric head HS = Suction height

Tolerance of characteristic curves in compliance with EN ISO 9906 App. A.

POS.	COMPONENT	CONSTRUCTION CHARACTERISTICS					
1	PUMP BODY	Cast iron, complete with threaded ports in compliance with ISO 228/1					
2	MOTOR BRACKET	Aluminium with brass insert (patented), reduces the risk of impeller seizure					
3	IMPELLER	Brass, with peripheral radial vanes					
4	MOTOR SHAFT	Stainless steel EN 10088-3 - 1.4104					
5	MECHANICAL SEAL	Pump	Seal	Shaft	Materials		
		<i>Model</i>	<i>Model</i>	<i>Diameter</i>	<i>Stationary ring</i>	<i>Rotational ring</i>	<i>Elastomer</i>
		PK 60-65-70-80	AR-12	Ø 12 mm	Ceramic	Graphite	NBR
		PK 90	FN-12	Ø 12 mm	Ceramic	Graphite	NBR
		PK 100-200-300	FN-14	Ø 14 mm	Graphite	Ceramic	NBR
6	BEARINGS	Pump	Model				
		PK 60-65	6201 ZZ / 6201 ZZ				
		PK 70-80-90	6203 ZZ / 6203 ZZ				
		PK 100-200-300	6204 ZZ / 6204 ZZ				
7	CAPACITOR	Pump	Capacitance				
		<i>Single-phase</i>	<i>(230 V or 240 V)</i>		<i>(110 V)</i>		
		PKm 60	10 µF 450 VL	25 µF 250 VL			
		PKm 65	14 µF 450 VL	30 µF 250 VL			
		PKm 70	16 µF 450 VL	60 µF 300 VL			
		PKm 80	20 µF 450 VL	60 µF 300 VL			
		PKm 90	20 µF 450 VL	60 µF 300 VL			
		PKm 100	31.5 µF 450 VL	60 µF 250 VL			
		PKm 200	45 µF 450 VL	80 µF 250 VL			
8	ELECTRIC MOTOR	<p>PKm: single-phase 230 V - 50 Hz with thermal overload protector built-in to the winding. PK: three-phase 230/400 V - 50 Hz.</p> <p>⇒ Pumps fitted with the three-phase motor option offer IE2 (IEC 60034-30) class high performance</p> <p>– Insulation: F class. – Protection: IP 44.</p>					

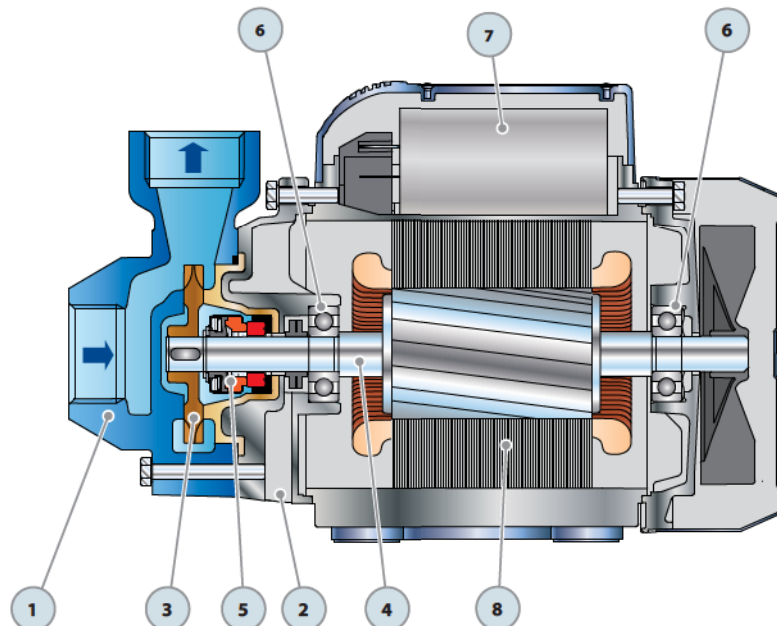

DIMENSIONS AND WEIGHT

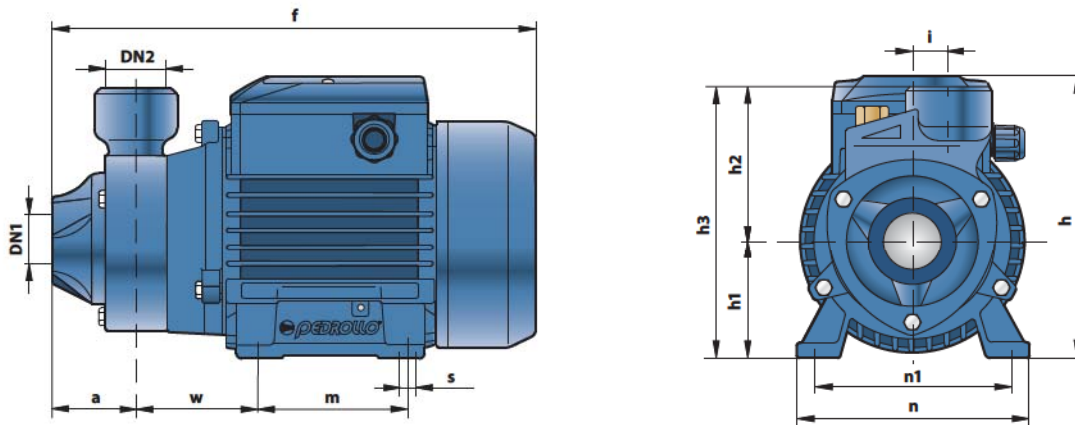

MODEL		PORTS		DIMENSIONS mm											kg		
Single-phase	Three-phase	DN1	DN2	a	f	h	h1	h2	h3	i	m	n	n1	w	s	1~	3~
PKm 60°	PK 60°	1"	1"	42	245	152	63	75	138	20	80	120	100	55	7	5.3	5.3
PKm 65	PK 65			80	143	6.9	6.4										
PKm 70	PK 70			55	285	180	71	85	156							10.1	9.0
PKm 80	PK 80			58	282	95	166	10.1	9.0								
PKm 90	PK 90	¾"	¾"	55	350	212	80	94	174		100	164	125	85	9	14.4	12.4
PKm 100	PK 100	1"	1"	55	350	212	80	94	174		100	164	125	85	9	15.5	13.4
PKm 200	PK 200			55	350	212	80	94	174		100	164	125	85	9	15.5	13.4
-	PK 300			-	-	-	-	-	-		-	-	-	-	-	-	-

ABSORPTION

MODEL	VOLTAGE (single-phase)		
Single-phase	230 V	240 V	110 V
PKm 60°	2.5 A	2.4 A	5.5 A
PKm 65	3.7 A	3.4 A	7.4 A
PKm 70	5.2 A	4.8 A	10.8 A
PKm 80	5.2 A	4.8 A	10.8 A
PKm 90	5.6 A	5.1 A	11.5 A
PKm 100	9.0 A	8.2 A	18.0 A
PKm 200	11.5 A	11.0 A	24.0 A

MODEL	VOLTAGE (three-phase)				
Three-phase	230 V	400 V	690 V	240 V	415 V
PK 60°	2.0 A	1.15 A	-	1.9 A	1.1 A
PK 65	3.0 A	1.7 A	-	2.8 A	1.6 A
PK 70	3.8 A	2.2 A	-	3.3 A	1.9 A
PK 80	3.8 A	2.2 A	-	3.3 A	1.9 A
PK 90	4.0 A	2.3 A	-	3.8 A	2.2 A
PK 100	6.2 A	3.6 A	2.05 A	5.7 A	3.3 A
PK 200	7.6 A	4.4 A	2.5 A	7.0 A	4.0 A
PK 300	9.3 A	5.4 A	3.15 A	8.7 A	5.0 A

PALLETIZATION

MODEL		GROUPAGE				CONTAINER			
Single-phase	Three-phase	n° pumps	H (mm)	1~	3~	n° pumps	H (mm)	1~	3~
PKm 60°	PK 60°	216	1420	1170	1170	324	2050	1740	1740
PKm 65	PK 65	216	1440	1510	1400	243	1600	1700	1580
PKm 70	PK 70	120	1300	1230	1100	180	1870	1840	1640
PKm 80	PK 80	120	1300	1230	1100	180	1870	1840	1640
PKm 90	PK 90	120	1300	1250	1130	180	1870	1860	1680
PKm 100	PK 100	72	1520	1060	910	84	1750	1230	1060
PKm 200	PK 200	72	1520	1140	990	84	1750	1320	1150
-	PK 300	72	1520	-	1140	84	1750	-	1330

